

820

LINEAR INTEGRATED CIRCUIT

1.2W AUDIO POWER AMPLIFIER

Description

The 820 is a monolithic integrated audio amplifier. It is designed for audio frequency class B amplifier.

Features

- *Wide operating supply voltage: $V_{cc}=3\sim 14V$
- *Medium output power
 $P_o=1.2W$ at $V_{cc}=9V, R_L=8\ \Omega, \text{Thd}=10\%$
- *Low quiescent circuit current: $I_{ccQ}=4mA$ (type)
- *Good ripple rejection.
- *Minimum number of external parts required.

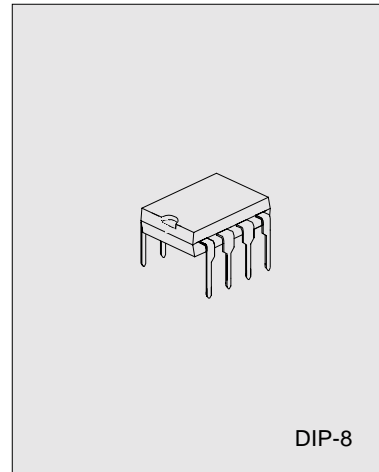

BLOCK DIAGRAM

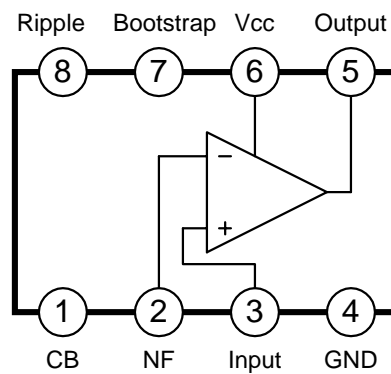

ABSOLUTE MAXIMUM RATINGS ($T_a=25^\circ C$)

Characteristic	Symbol	Value	Unit
Supply Voltage	V_{cc}	16	V
Output Peak Current	I_{peak}	1.5	A
Power Dissipation	P_D	1.25	W
Operating Temperature	T_{opr}	-20 ~ +70	$^\circ C$
Storage Temperature	T_{stg}	-40 ~ +150	$^\circ C$

TYPICAL CHARACTERISTIC PERFORMANCE

Fig 1 Quiescent circuit current vs Supply Voltage

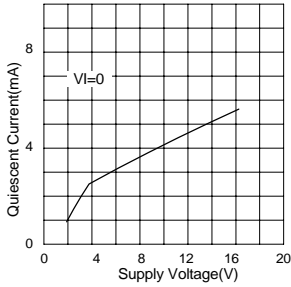

Fig 2 Output power vs Supply Voltager

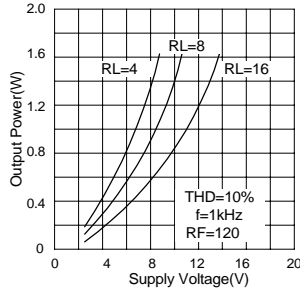

Fig 3 Total harmonic Distortion vs Output power

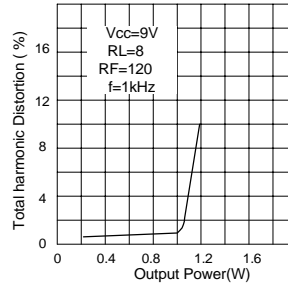

Fig 4 Voltage Gain vs Feedback resistance

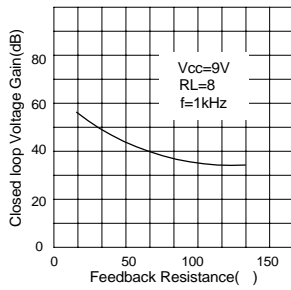

Fig 5 Power Dissipation vs Output power

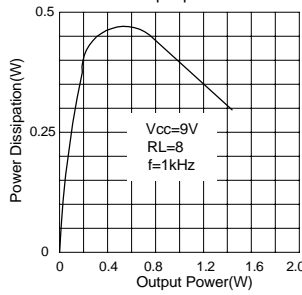

Fig 6 Power Dissipation vs Supply Voltage

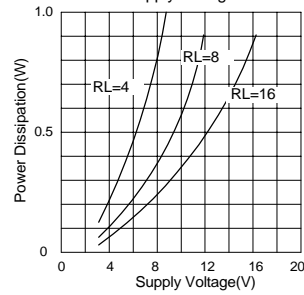

Fig 7 Frequency response

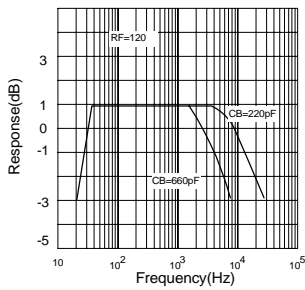

Fig 8 Total Harmonic distortion vs frequency

