

10W CAR RADIO AUDIO AMPLIFIER

DESCRIPTION

The 2003 has improved performance with the same pin configuration as the 2002. The additional features of 2002, very low number of external components, ease of assembly, space and cost saving, are maintained.

The device provides a high output current capacity (up to 3.5A) very low harmonic and crossover distortion. Completely safe operation is guaranteed due to protection against DC and AC short circuit between all pins and ground, thermal over-range, load dump voltage surge up to 40V and fortuitous open ground.

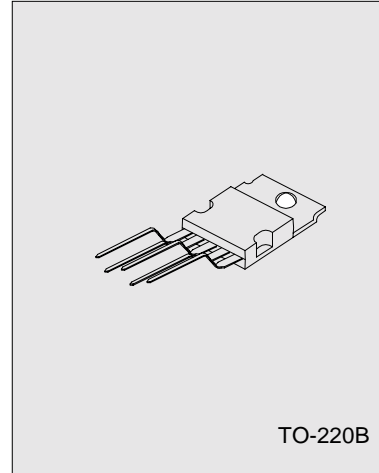

TO-220B

ABSOLUTE MAXIMUM RATINGS ($T_a=25^{\circ}\text{C}$)

CHARACTERISTICS	SYMBOL	VALUE	UNITS
Peak Supply Voltage	V_s	40	V
DC supply Voltage	V_s	28	V
Operating supply voltage	V_s	18	V
Output peak current (repetitive)	I_o	3.5	A
Output peak current (non repetitive)	I_o	4.5	A
Power dissipation at $T_{case}=90^{\circ}\text{C}$	P_{tot}	20	W
Storage temperature	T_{stg}	-40~+150	$^{\circ}\text{C}$
junction temperature	T_j	-40~+150	$^{\circ}\text{C}$

Pin Connection

- 1 Non inverting input
- 2 Inverting input
- 3 Ground
- 4 Output
- 5 Supply Voltage

Test Circuit

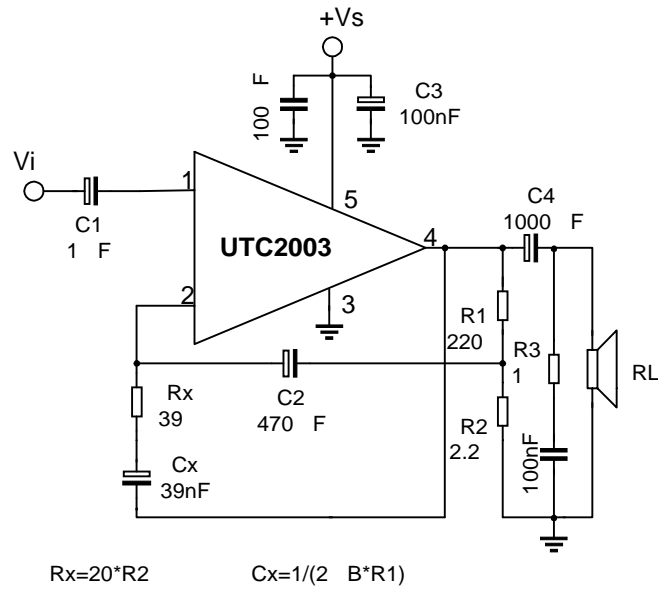

Schematic Diagram

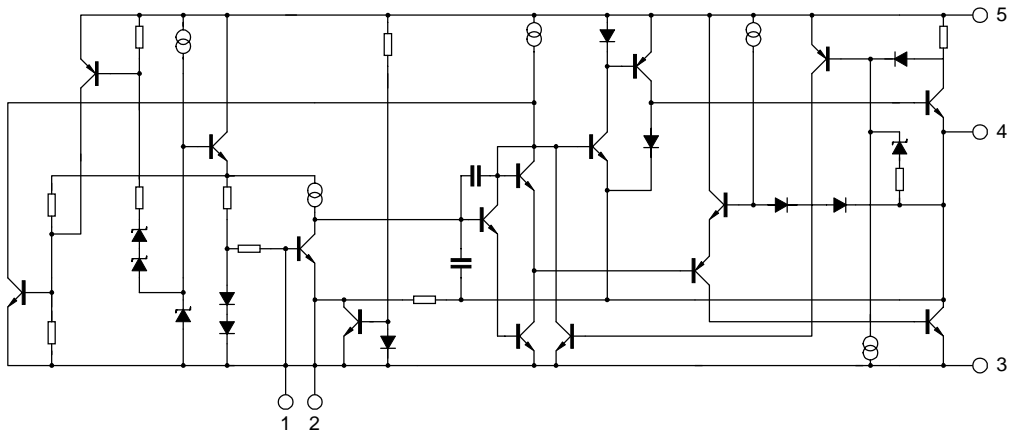

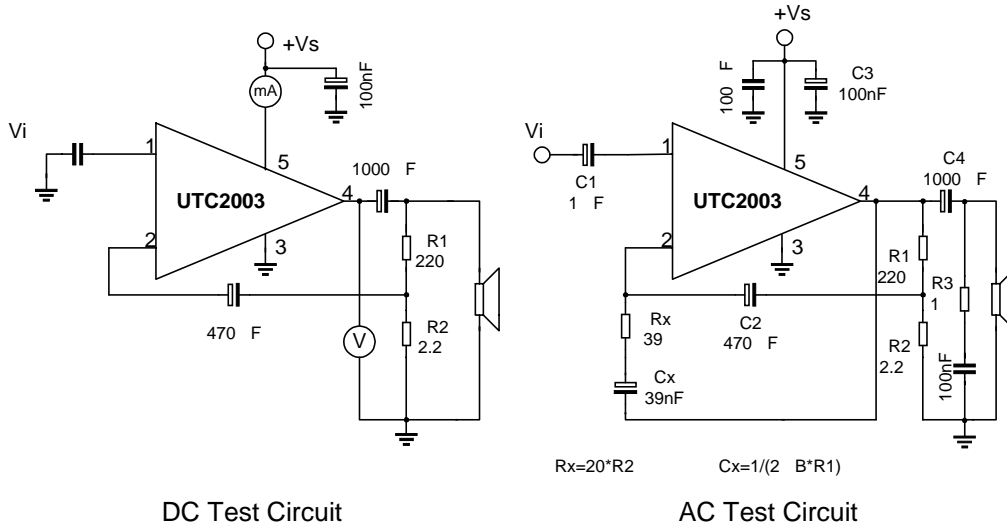

CHARACTERISTICS (Refer to the test circuit, $V_s = \pm 16V, T_a = 25^\circ C$)

PARAMETER	SYMBOL	TEST CONDITIONS	MIN	TYP	MAX	UNIT
DC CHARACTERISTICS						
Supply Voltage	V_s		8		18	V
Quiescent Output Voltage	V_o		6.1	6.9	7.7	V
Quiescent drain current	I_d			44	50	mA
AC CHARACTERISTICS						
Output power	P_o	d=10%, f=1kHz				W
		RL=8 Ω	5.5	6		
		RL=2 Ω	9	10		
		RL=3.2 Ω		7.5		
Input sensitivity	V_i	f=1kHz				mV
		$P_o=0.5W, R_L=4 \Omega$		14		
		$P_o=6W, R_L=4 \Omega$		55		
		$P_o=0.5W, R_L=2 \Omega$		10		
Input saturation voltage	$V_i(rms)$			300		mV
Frequency response(-3dB)	B	$P_o=1W, R_L=4 \Omega$	40		15000	Hz
Distortion	D	f=1kHz				%
		$P_o=0.05$ to $4.5W, R_L=4 \Omega$		0.15		
		$P_o=0.05$ to $7.5W, R_L=2 \Omega$		0.15		

(continued)

PARAMETER	SYMBOL	TEST CONDITIONS	MIN	TYP	MAX	UNIT
-----------	--------	-----------------	-----	-----	-----	------

2003

LINEAR INTEGRATED CIRCUIT

Input Resistance(pin 1)	R _i	open loop, f=1kHz	70	150		k Ω
Input noise current	e _N			60	200	pA
Input noise voltage	I _N			1	5	μ V
open loop voltage gain	G _{vo}	f=1kHz		80		dB
		f=10kHz		60		dB
closed loop voltage gain	G _{vc}	f=1kHz				
		RL=4 Ω	39.3	40	40.3	dB
Efficiency	η	f=1kHz				
		P _o =6W, RL=4 Ω		69		%
		P _o =10W, RL=2 Ω		65		%
Supply voltage rejection	SVR	f=100Hz, V _{ripple} =0.5V R _g =10k Ω, RL=4 Ω	30	36		dB

Fig.1 Quiescent output voltage vs. Supply voltage

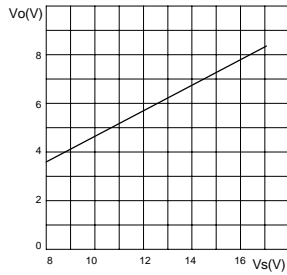

Fig.2 Quiescent drain current vs. Supply voltage

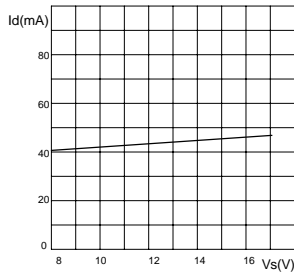

Fig.3 Output power vs. Supply voltage

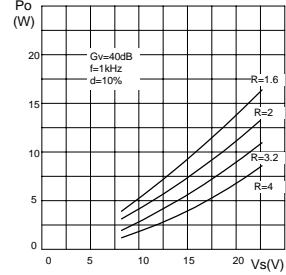

Fig.4 output power vs. load resistance

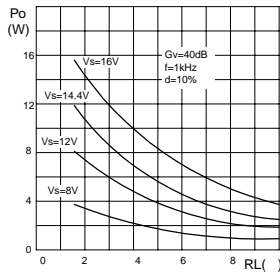

Fig.5 Gain vs. Input sensitivity

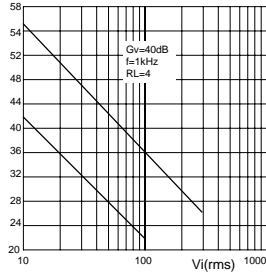

Fig.6 Gain vs. Input sensitivity

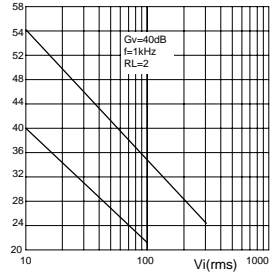

Fig.7 Distortion vs. output power

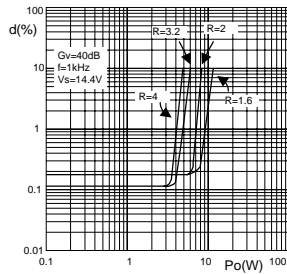

Fig.8 Distortion vs. frequency

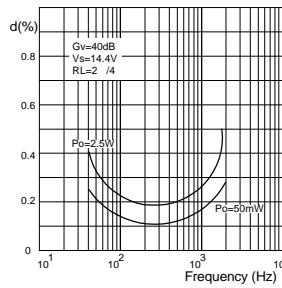
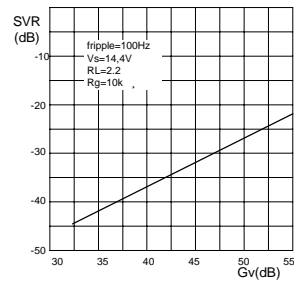
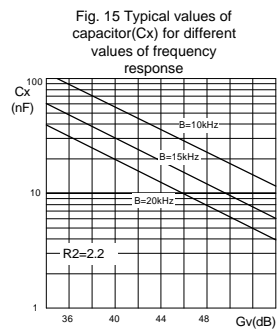
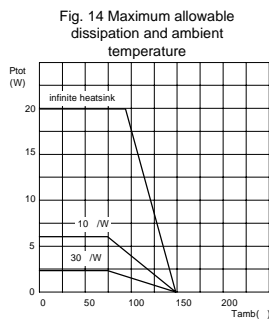
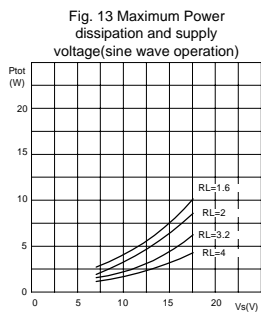
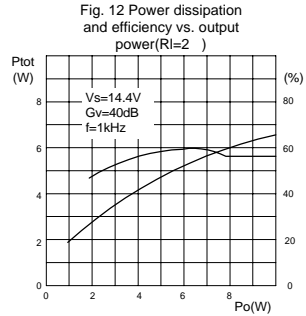
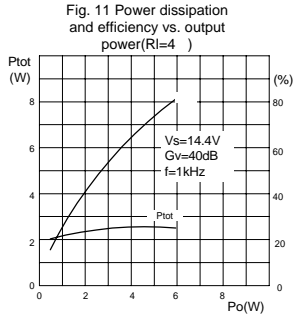
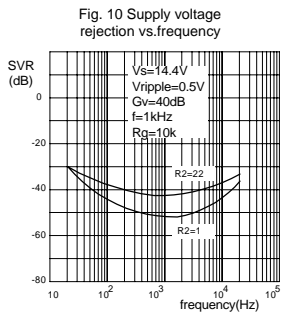

Fig.9 Supply voltage rejection vs. voltage gain





Application Information

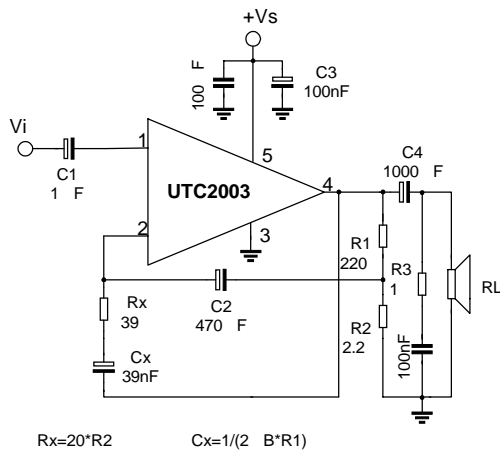

Fig 16 Typical application circuit

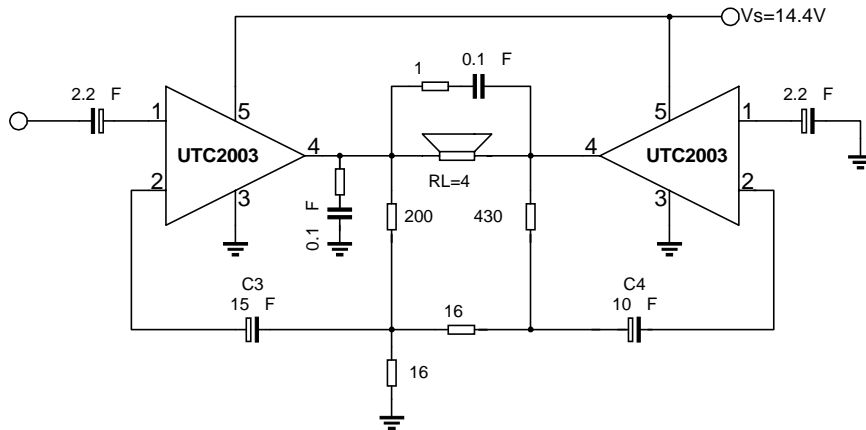

Fig.18 20W Bridge configuration application

The Values of the capacitors C3 and C4 are different to optimize the SVR(Typ. 40dB)

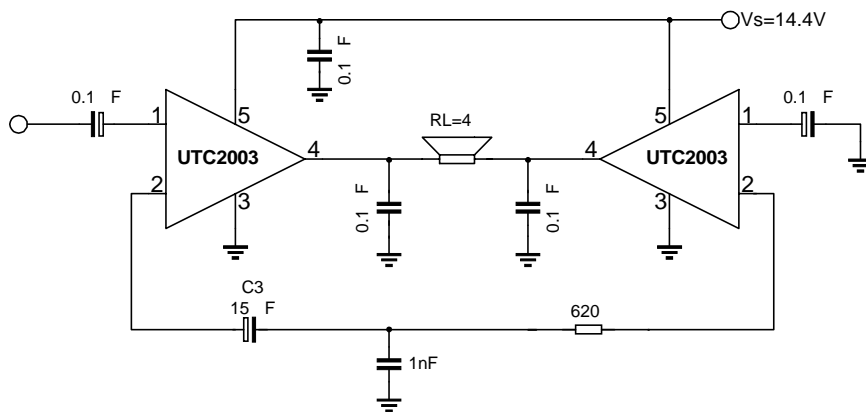

Fig.20 Low cost bridge configuration application circuit($P_o=18W$)

Built-in protection systems

Load dump voltage surge

The 2003 has a circuit which enables it to withstand a voltage pulse train, on pin 5, of the type shown in Fig. 23.

If the supply voltage peaks to more than 40V, then an LC filter must be inserted between the supply and pin 5, in order to assure that the pulses at pin 5 will be held within the limits shown in Fig.22.

A suggested LC network is shown in Fig.23. With this network, a train of pulses with amplitude up to 120V and width of 2ms can be applied at point A. This type of protection is ON when the supply voltage (pulsed or DC) exceeds 18V. For this reason the maximum operating supply voltage is 18V.

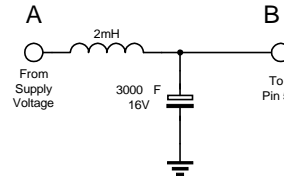
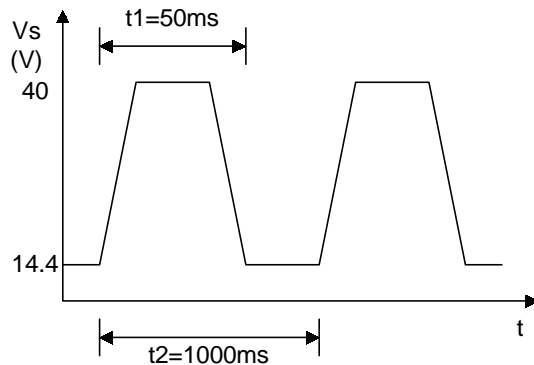

Short Circuit (AC and DC Conditions)

The 2003 can withstand a permanent short-circuit on the output for a supply voltage up to 16V.

Polarity inversion

High current (up to 5A) can be handled by the device with no damage for a longer period than the blow-out time of a quick 1A fuse (normally connected in series with the supply).

The feature is added to avoid destruction if, during fitting to the car, a mistake on connection of the supply is made.

Open ground

When the radio is in the ON condition and the ground is accidentally opened, a standard audio amplifier will be damaged. On the 2003 protection diodes are included to avoid any damage.

Inductive load

A protection diode is provided between pin 4 and pin 5 (see the internal schematic diagram) to allow use of the 2003 with inductive loads. In particular, the 2003 can drive a coupling transformer for audio modulation.

DC voltage

The maximum operating DC voltage on the 2003 is 18V.

However, the device can withstand a DC voltage up to 28V with no damage. This could occur during winter if two batteries were series connected to crank the engine.

Thermal shut-down

The presence of a thermal limiting circuit offers the following advantages:

- 1). an overload on the output (even if it is permanent), or an excessive ambient temperature can be easily withstood.
- 2). the heat-sink can have a smaller factor compared with that of a conventional circuit. There is no device damage in case of excessive junction temperature: all that happens is that P_o (and there P_{tot}) and I_d are reduced.

Application suggestion

The recommended values of the components are those shown on application circuit of Fig.16. Different values can be used. The following table can help the designer.

Component	Recommended value	Purpose	Large than recommended value	Large than recommended value
R1	$(Gv-1)*R2$	gain setting.		increase of Gain
R2	2.2 Ω	gain and SVR setting.	Decrease of SVR	
R3	1 Ω	Frequency stability	Danger of oscillation at high frequencies with inductive loads.	
Rx	$\approx 20R2$	Upper frequency cutoff	Poor high frequencies attenuation	Dange of oscillation
C1	2.2 μ F	Input DC decoupling		Noise at switch-on switch-off
C2	470 μ F	Ripple rejection		Decrease of SVR
C3	0.1 μ F	Supply voltage bypass		Dange of oscillation
C4	100 μ F	Supply voltage bypass		Higher low frequency cutoff
C5	0.1 μ F	Frequency stability		Danger of oscillation at high frequencies with inductive loads.
Cx	$\approx 1/(2 \pi *B*R1)$	Upper frequency cutoff	smaller bandwidth	Larger bandwidth